

2A6Z Gear Damper

SOC Free
Made in Japan

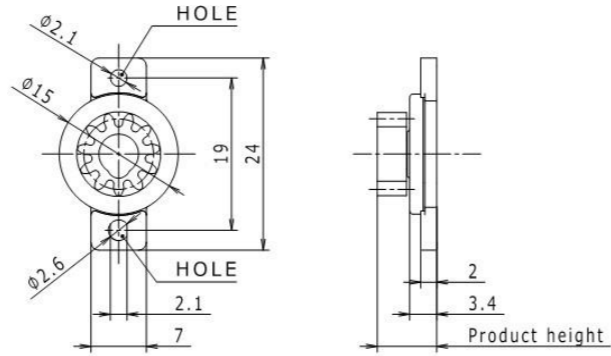
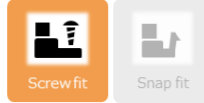

◆ Characteristics

- ✓ Torque : 7 types
- ✓ Gear : 3 types
- ✓ Low VOC

◆ Component parts

Part name	Material
HOUSING	PC
ROTOR	POM
CAP	PC
GEAR	Table below
O-RING	EPDM
OIL	SILICONE

● GEAR Specification

Type	11T	11	16
Number of teeth	11	11	16
Tooth width	2.6	3.6	4.4
Product height	6.5	7.5	8
Module	0.8	0.8	0.8
Pitch circle diameter	φ8.8	φ8.8	φ12.8
Pressure angle	20°	20°	20°
Material	PA66	PA66	PA66

Involute full depth

◇ Part number/Specifications

● Part number	Torque [mN·m]	0	2	4	6	8	10	12	14	16	18	20	22	24	26
2A6Z - 03	2.5 ± 0.8														
2A6Z - 04	4.0 ± 1.0														
2A6Z - 07	7.0 ± 1.2														
2A6Z - 10	10.0 ± 1.4														
2A6Z - 14	13.5 ± 1.6														
2A6Z - 16	16.5 ± 2.5														
2A6Z - 23	23.0 ± 3.0														

Speed : 20r/min

● Durability

Conditions 1 cycle : One rotation (3/2 turn) / 1s → pause / 1s → Reverse rotation (3/2 turn) / 1s → pause / 1s
Lifetime 50,000 cycles Room temperature (23°C)

◇ Damper characteristics

● Rotation speed - torque characteristic (23°C)

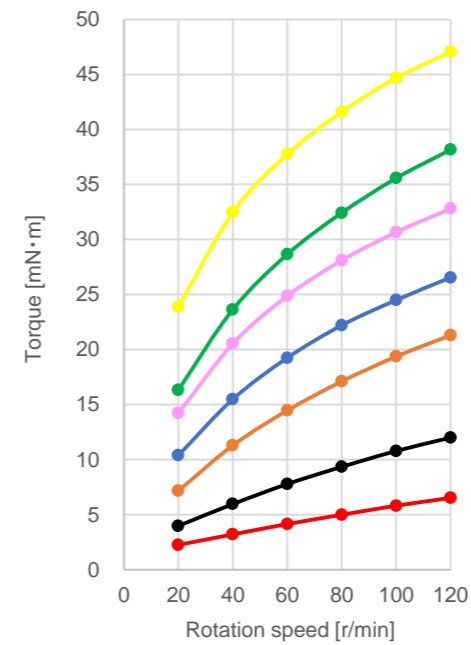

● Temperature - torque characteristic (20r/min)

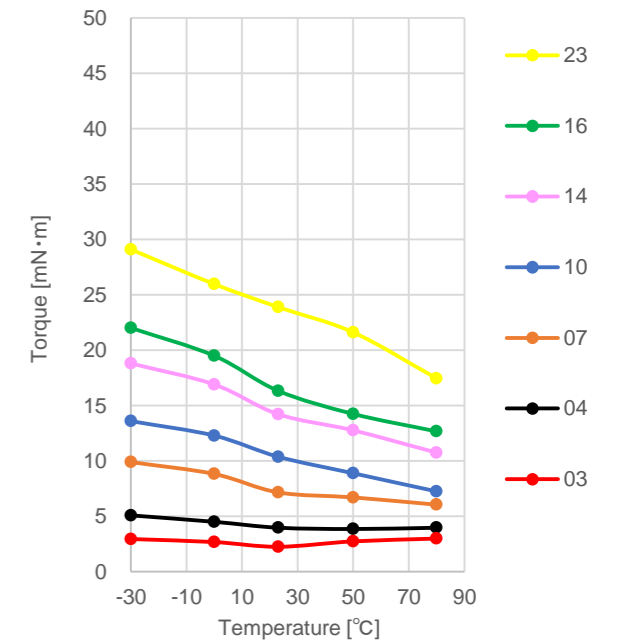

※ Specifications are subject to change without notice.