

058S High Torque Gear Damper

SOC Free

Made in Japan

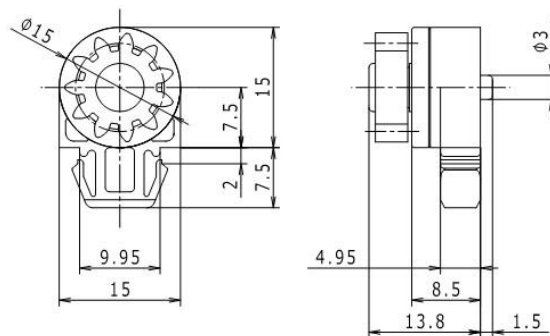
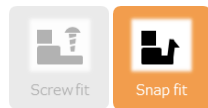

◆ Characteristics

- ✓ $\Phi 15$ size high torque
- ✓ Torque : 2 types

◆ Component parts

Part name	Material
HOUSING	PC
ROTOR	POM
CAP	PC
GEAR	POM
O-RING	VMQ
OIL	SILICONE

◆ GEAR Specification

Item	Specification
Number of teeth	11
Tooth width	4
Module	0.8
Pitch circle diameter	$\phi 11$
Pressure angle	20°
Addendum modification coefficient	+0.3

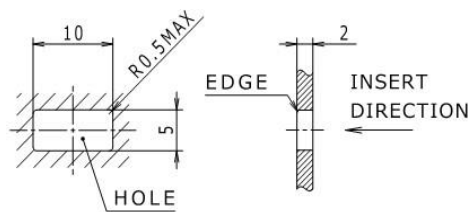

Involute full depth

◇ Part number/Specifications

Part number	Torque [mN·m]	0	5	10	15	20	25	30	35	40	45	50	55	60	65
058S - 23	22.54 ± 3.93														
058S - 47	46.55 ± 4.90														

Speed : 20r/min

● Durability

Conditions	1 cycle : One rotation (1/2 turn) / 1s → pause / 1s → Reverse rotation (1/2 turn) / 1s → pause / 1s	
Lifetime	20,000 cycles	Room temperature (23°C)

◇ Damper characteristics

● Rotation speed - torque characteristic (23°C)

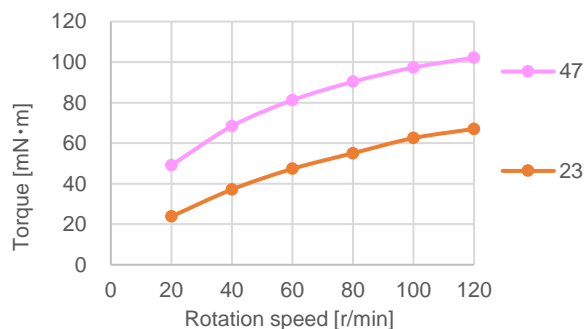

● Temperature - torque characteristic (20r/min)

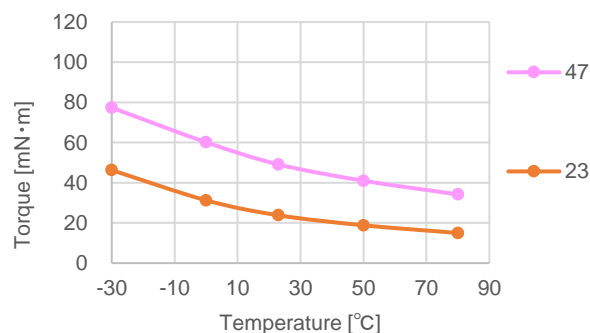

※ Specifications are subject to change without notice.